

COOLING PIPES

— BRASS/STAINLESS TYPE —



Printed in Red

The volume discount rate is also applicable to alteration cost.
All price & lead time are to be quoted.

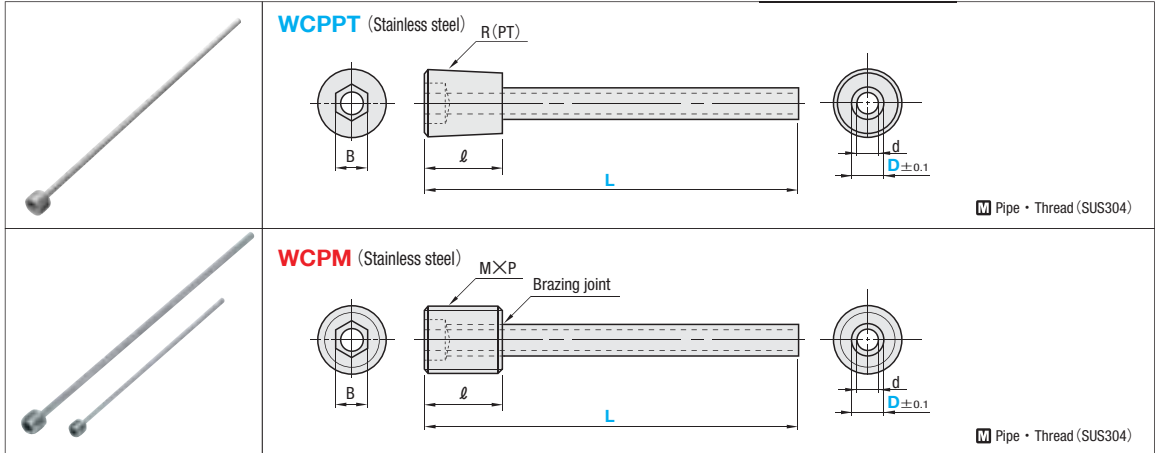

R (PT)	M×Pitch	B		ℓ		d		Catalog No.		L	U/Price				
WCPPT	WCPM	WCPPT	WCPM	WCPPT	WCPM	WCPPT	WCPM	Type	D		WCPPT	WCPM			
1/8	M 6×1.0	5	3	7	6	1.6		WCPPT (Stainless steel)	2	150					
						2.5									
	M 8×1.25		4		8	3.6		WCPM (Stainless steel)		4	200	250	Quotation		
						2.00									
											300				

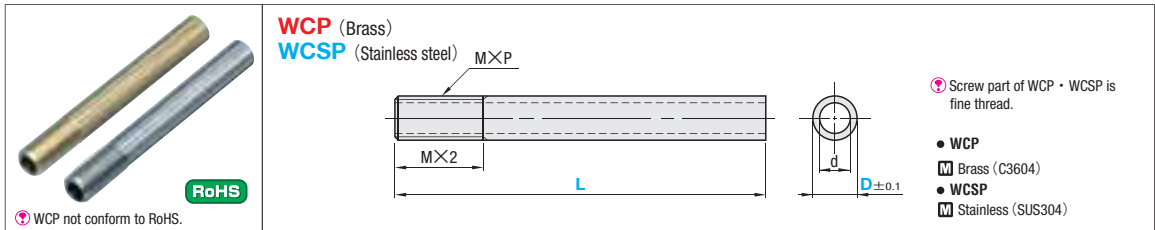

M×Pitch (Fine thread)	d	Catalog No.		L		U/Price for 1~19	
		Type	D	WCP	WCPSP	WCP	WCPSP
M3×0.35	1.0	WCP (Brass) WCPSP (Stainless steel)	3	10	50	100	Quotation
					150	200	
M4×0.5	2.0		4		50	100	
					150	200	
M5×0.5	3.0		5		50	100	
					150	200	
					250	300	
					50	100	
M6×0.75	4.0		6		150	200	
					250	300	
		50		100			
M8×0.75	5.0	8	150	200			
			250	300			
			50	100			
M10×1.0	7.0	10	150	200			
			250	300			

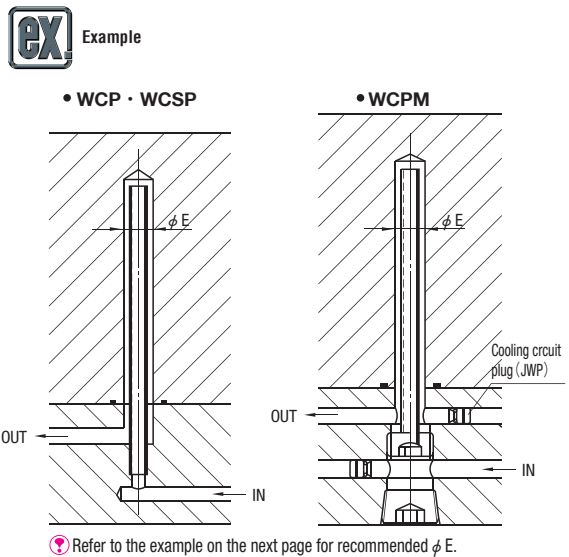

Refer to the example on the next page for recommended φ E.

Order

Catalog No.	L
WCPPT3	200
WCPSP 6	150
WCPM 2	150

Delivery

SGP Stock	3 Days
-----------	--------

For area out of Singapore please refer to P.i.

Quantity discount rate

Quantity	1~19	20~29	30~49	50~100
Rate	—	5%	10%	15%